

FRE129 _REV10

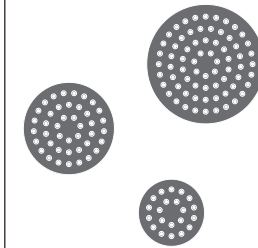

FRE129/FREE IDEAS

AISI 316/L STAINLESS STEEL

Composizione di soffioni doccia ad incasso con ugelli in silicone trasparente

Built-in shower head set with transparent silicone nozzles

CEA DESIGN STUDIO

+ Prodotto che necessita di parte incasso
Product that needs built-in part

MANUTENZIONE / MAINTENANCE

NON UTILIZZARE DO NOT USE		acido clorico e muriatico <i>chloric and muriatic acid</i>
		acido fluoridrico <i>hydrofluoric acid</i>
		ipoclorito di sodio <i>chlorine bleach</i>
UTILIZZARE TO USE		sapone a PH neutro <i>neutral PH soap</i>

Questi disegni sono proprietà di CEADDESIGN SRL s.u. pertanto non potranno essere utilizzati e/o comunicati a terzi, anche in forma parziale, senza preventiva autorizzazione. CEADDESIGN SRL s.u. si riserva il diritto di apportare modifiche ai disegni al fine di migliorare il prodotto.

CEADDESIGN SRL s.u. has the property rights on these drawings, therefore they cannot be used and/or transferred to third party, even in partial form, without any prior authorization. Furthermore CEADDESIGN SRL s.u. reserves the right to apply any change to these drawings in order to upgrade the product.



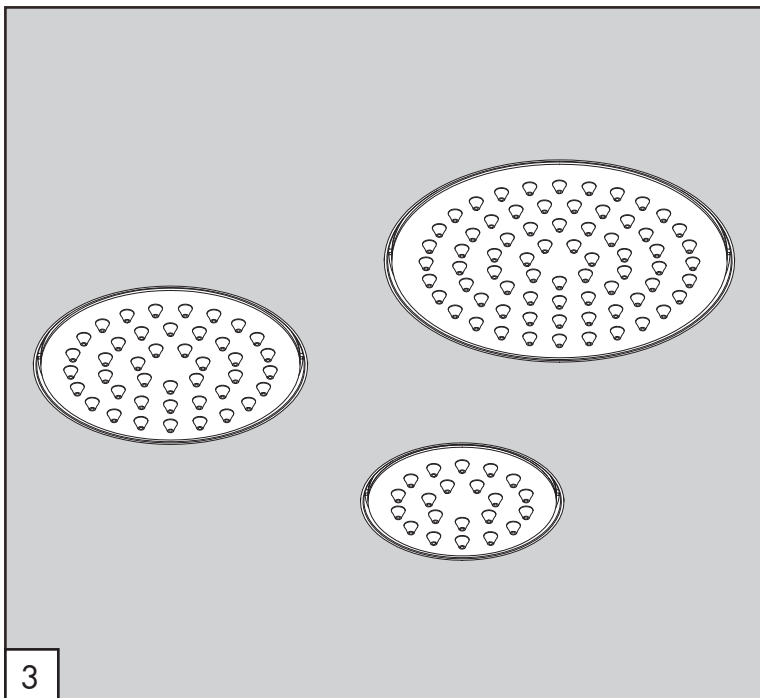
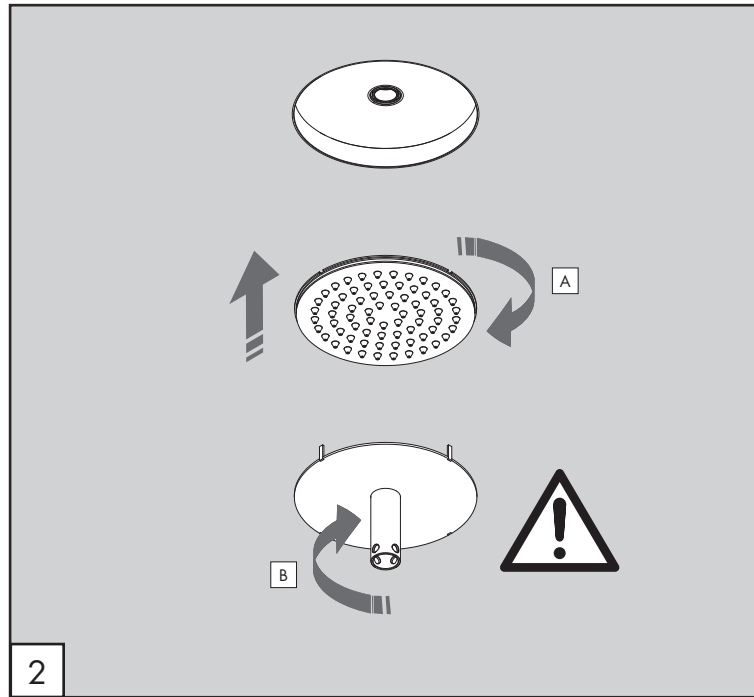
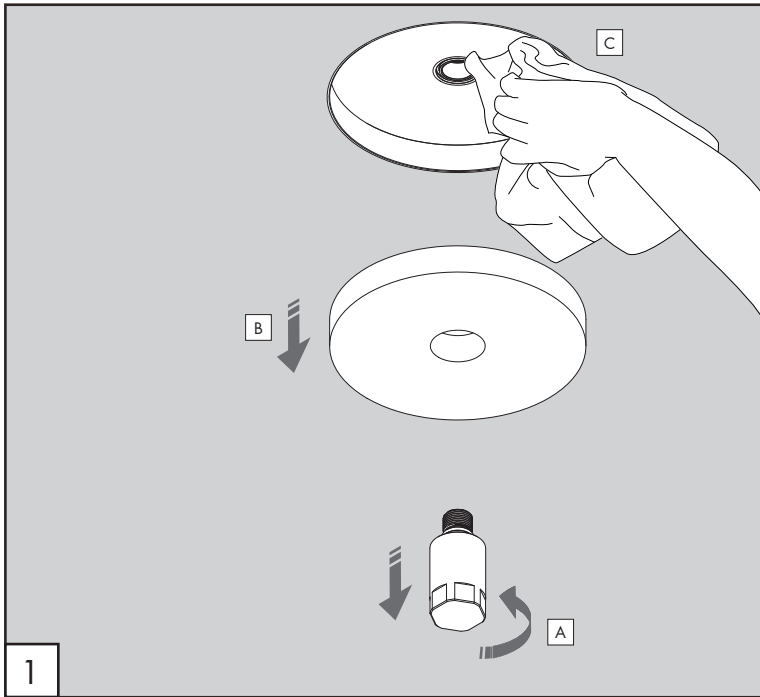

PULIZIA / CLEANING / SAUBEKEIT / LIMPIEZA / NETTOYAGE

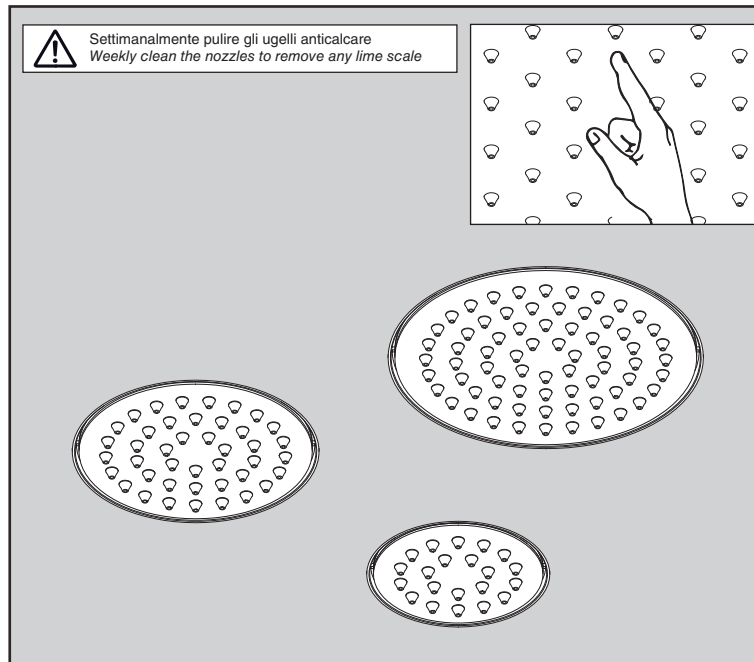

AVVERTENZE TECNICHE

Risciacquare bene le tubazioni prima del montaggio ed evitare sbalzi di pressione.

In caso di pressioni statiche superiori a 5 bar si raccomanda l'installazione di un riduttore di pressione per evitare danni al soffione.

TECHNICAL WARNINGS

The pipes have to be rinsed thoroughly before installation to avoid pressure differences.

Use of a pressure reducer when static pressure is higher than 5 bar to avoid damage of the shower head.

TECHNISCHE WARNUNG

Spülen Sie die Leitungen vor dem Einbau und verhindern Sie Wasserdruckwechsel.

Wenn Wasserdruck größer als 5 bar ist, bitte reduzieren Sie den Systemdruck, um Beschädigung der Kopfbrause zu verhindern.

ADVERTENCIA TÉCNICA

Purgar bien las tuberías antes de la instalación y evitar cambios bruscos de presión.

En caso de presión estática mayor de 5 bar, se recomienda el uso de un adaptador de presión para evitar daños en el rociador.

ADVERTISSEMENTS TECHNIQUES

Rincer les tuyaux avant l'installation. Eviter grandes différences de pression.

En cas de pressions statique de plus de 5 bar, nous vous recommandons d'installer un réducteur de pression pour éviter des dommages à la douche de tête.

CARATTERISTICHE TECNICHE / TECHNICAL FEATURES

Portata minima ottimale <i>Optimum minimum flow rate</i>	l/min 15	gal/min 4
---	-------------	--------------

Peso prodotto senza acqua <i>Product weight without water *</i>	Kg 0,67	
--	------------	--

* Peso senza parte ad incasso / *Weight without built-in part*

Le portate indicate sono alla pressione consigliata di 3 bar

The indicated flow rates are at the recommended pressure of 3 bar