

FRE183

_REV10

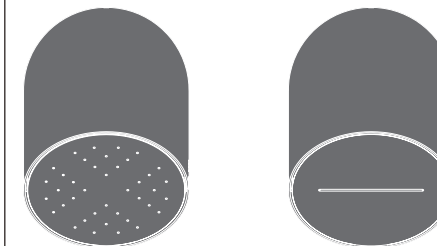

FRE183/FREE IDEAS

AISI 316/L STAINLESS STEEL

Composizione di soffioni doccia orientabili,
estremità in Delrin® con getto a pioggia e a cascata





*Adjustable shower head set,
Delrin® end with rain and waterfall jet*

CEA DESIGN STUDIO

 Staffa ausiliaria per cartongesso / fibrogesso
Auxiliary bracket for plasterboard / fiber-board structures

FIX Staffa ausiliaria per cartongesso / fibrogesso
Auxiliary bracket for plasterboard / fiber-board structures

MANUTENZIONE / MAINTENANCE

NON UTILIZZARE DO NOT USE		acido clorico e muriatico <i>cloric and muriatic acid</i>
		acido fluoridrico <i>hydrofluoric acid</i>
		ipoclorito di sodio <i>chlorine bleach</i>
UTILIZZARE TO USE		sapone a PH neutro <i>neutral PH soap</i>

Questi disegni sono proprietà di CEADESIGN SRL s.u. pertanto non potranno essere utilizzati e/o comunicati a terzi, anche in forma parziale, senza preventiva autorizzazione. CEADESIGN SRL s.u. si riserva il diritto di apportare modifiche ai disegni al fine di migliorare il prodotto.

CEADESIGN SRL s.u. has the property rights on these drawings, therefore they cannot be used and/or transferred to third party, even in partial form, without any prior authorization. Furthermore CEADESIGN SRL s.u. reserves the right to apply any change to these drawings in order to upgrade the product.

CEA

ceadesign.it

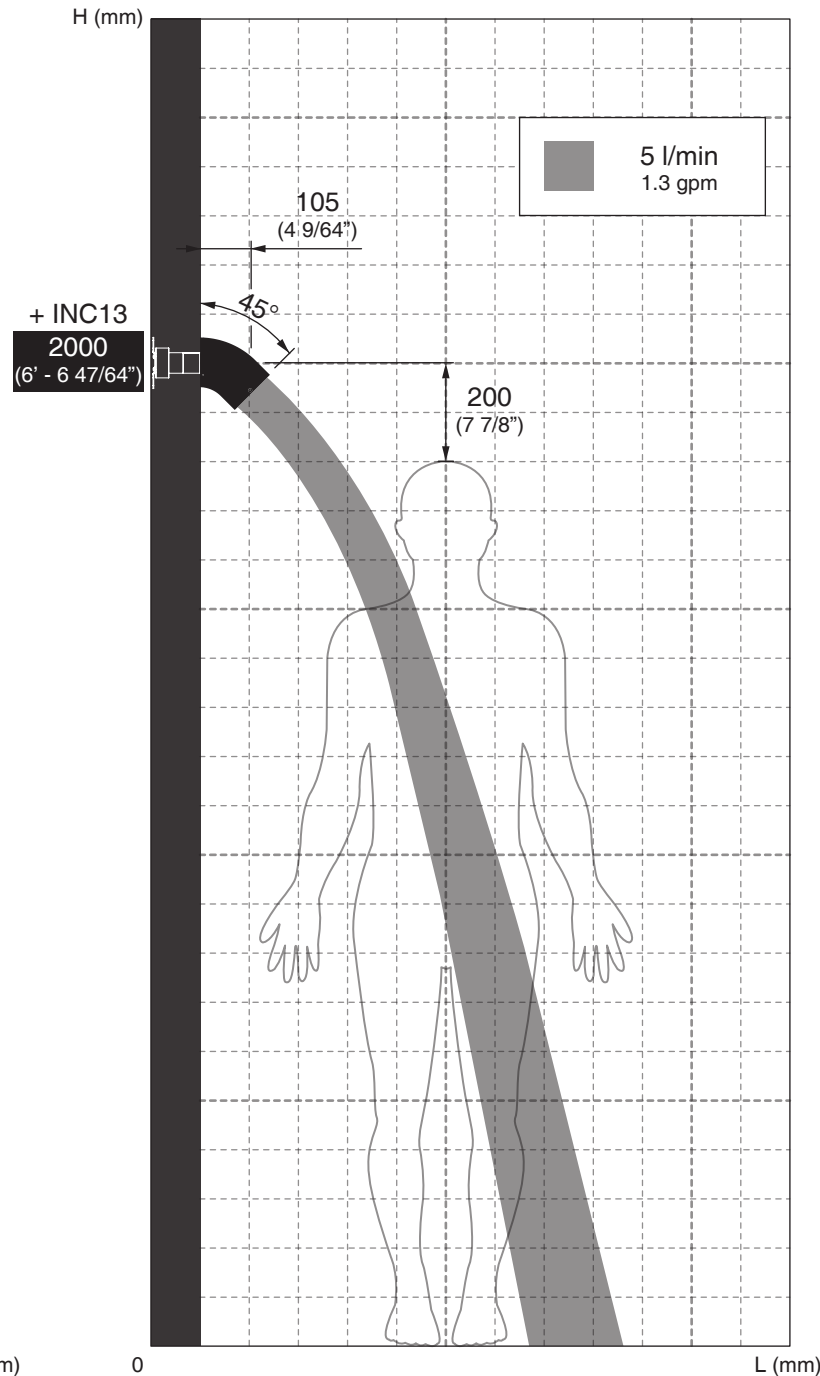
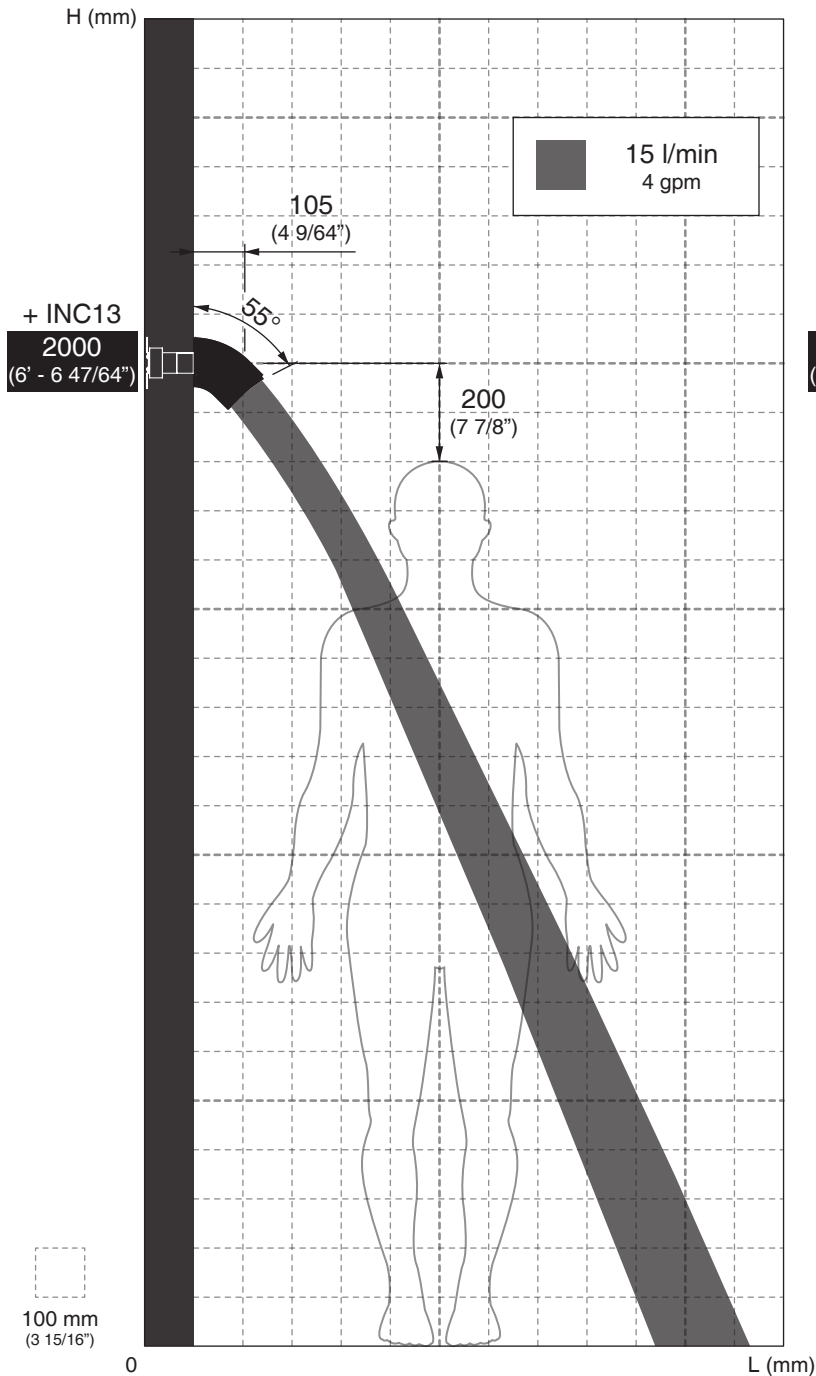

FRE183

_REV10

AVVERTENZE DI INSTALLAZIONE

L'altezza ottimale di installazione del prodotto si determina in base all'altezza dell'utente.
La rappresentazione ha valore puramente indicativo.

INSTALLATION WARNINGS

Each individual product has to be installed and adjusted to suit the user's height.
The representation is purely indicative.

INSTALLATIONS WARNING

Die optimale Anbringungshöhe der einzelnen Produkte ist abhängig von der Körpergröße der Benutzer.
Die Zeichnung ist rein indikativ.

ADVERTENCIAS DE INSTALACIÓN

La altura de colocación ideal de cada producto se determina conforme a la altura de la persona.
La representación es indicativa.

AVERTISSEMENTS D'INSTALLATION

La hauteur optimale de l'emplacement du produit est à déterminer selon la taille de la personne.
La représentation est purement indicative.

Le portate indicate sono alla pressione consigliata di 3 bar
The indicated flow rates are at the recommended pressure of 3 bar

PORTATA MASSIMA / MAXIMUM FLOW RATE *

Getto a pioggia / Rain jet

15 l/min / 4 gpm

PORTATA MINIMA / MANIMUM FLOW RATE *

Getto a pioggia / Rain jet

5 l/min / 1.3 gpm

* Il flusso è determinato dalla portata del comando abbinato
The flow is determined by the range of the combined control

SU RICHIESTA / ON DEMAND



Riduttore di portata / Flow regulator
5 l/min / 1.3 gpm

CEA

GETTO A CASCATA / WATERFALL JET

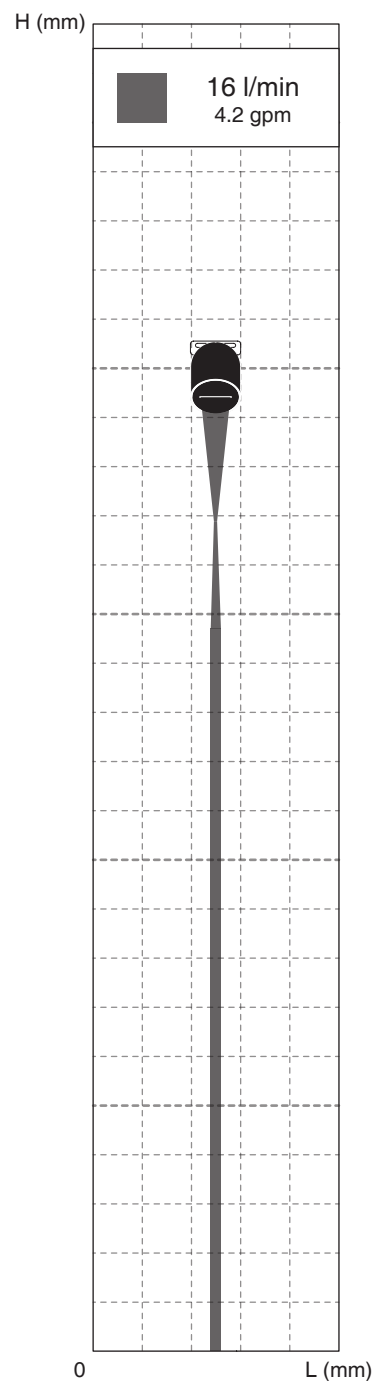
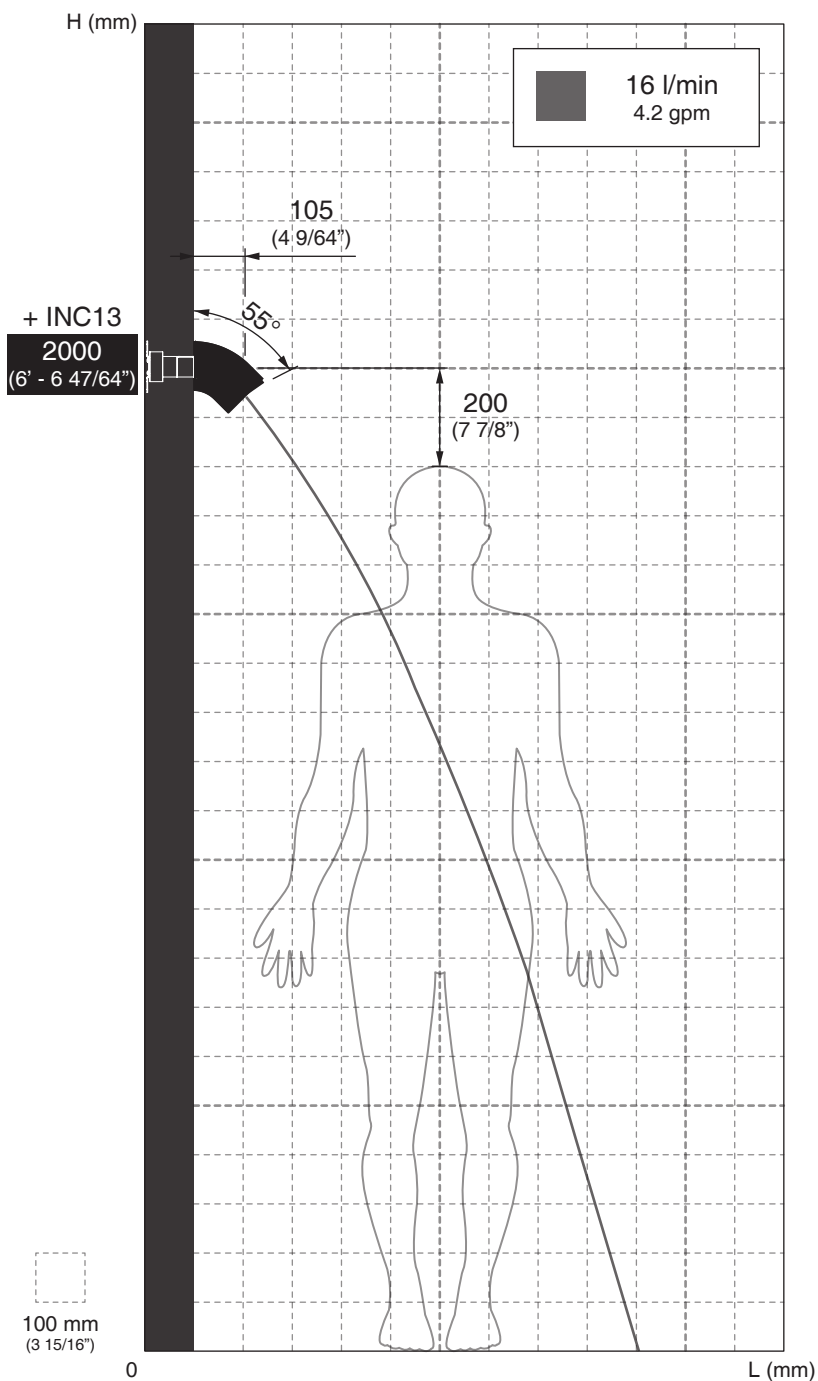

FRE183

_REV10

AVVERTENZE DI INSTALLAZIONE

L'altezza ottimale di installazione del prodotto si determina in base all'altezza dell'utente.
La rappresentazione ha valore puramente indicativo.

INSTALLATION WARNINGS

Each individual product has to be installed and adjusted to suit the user's height.
The representation is purely indicative.

INSTALLATIONS WARNING

Die optimale Anbringungshöhe der einzelnen Produkte ist abhängig von der Körpergröße der Benutzer.
Die Zeichnung ist rein indikativ.

ADVERTENCIAS DE INSTALACIÓN

La altura de colocación ideal de cada producto se determina conforme a la altura de la persona.
La representación es indicativa.

AVERTISSEMENTS D'INSTALLATION

La hauteur optimale de l'emplacement du produit est à déterminer selon la taille de la personne.
La représentation est purement indicative.

Le portate indicate sono alla pressione consigliata di 3 bar
The indicated flow rates are at the recommended pressure of 3 bar

PORTATA MASSIMA / MAXIMUM FLOW RATE *

Getto a cascata / Waterfall jet
16 l/min / 4.2 gpm

* Il flusso è determinato dalla portata del comando abbinato
The flow is determined by the range of the combined control

CEA

GETTO A CASCATA / WATERFALL JET

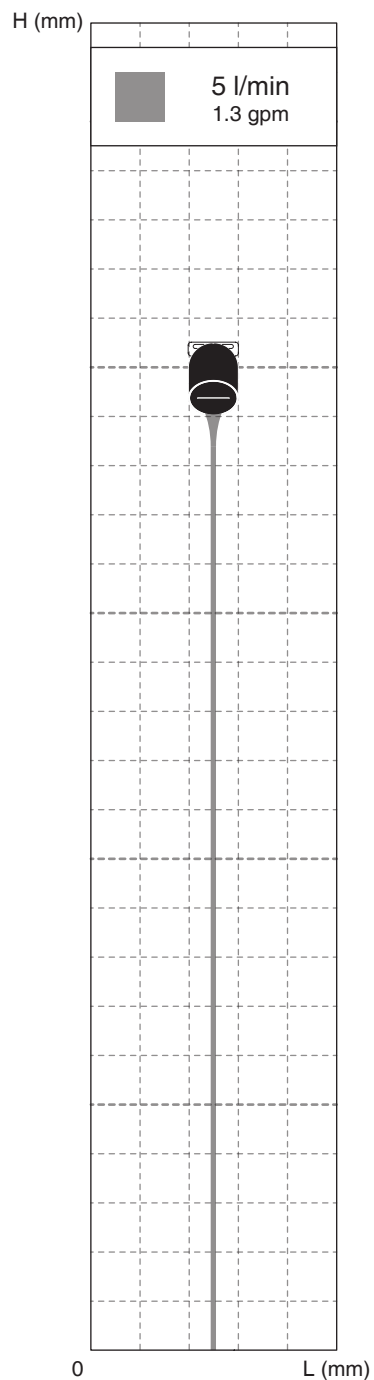
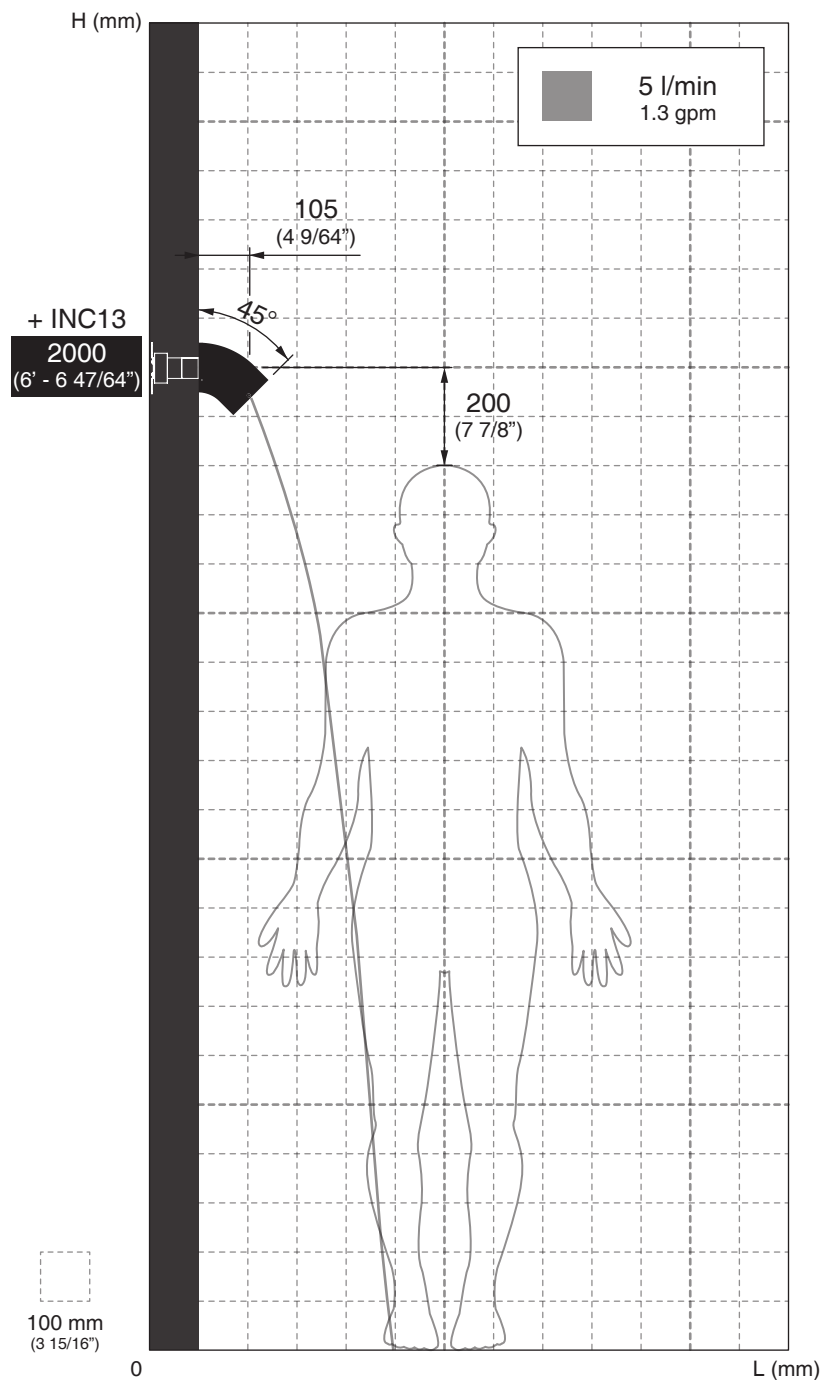

FRE183

_REV10

AVVERTENZE DI INSTALLAZIONE

L'altezza ottimale di installazione del prodotto si determina in base all'altezza dell'utente.
La rappresentazione ha valore puramente indicativo.

INSTALLATION WARNINGS

Each individual product has to be installed and adjusted to suit the user's height.
The representation is purely indicative.

INSTALLATIONS WARNING

Die optimale Anbringungshöhe der einzelnen Produkte ist abhängig von der Körpergröße der Benutzer.
Die Zeichnung ist rein indikativ.

ADVERTENCIAS DE INSTALACIÓN

La altura de colocación ideal de cada producto se determina conforme a la altura de la persona.
La representación es indicativa.

AVERTISSEMENTS D'INSTALLATION

La hauteur optimale de l'emplacement du produit est à déterminer selon la taille de la personne.
La représentation est purement indicative.

Le portate indicate sono alla pressione consigliata di 3 bar
The indicated flow rates are at the recommended pressure of 3 bar

PORTATA MINIMA / MANIMUM FLOW RATE *

Getto a cascata / Waterfall jet
5 l/min / 1.3 gpm

* Il flusso è determinato dalla portata del comando abbinato
The flow is determined by the range of the combined control

SU RICHIESTA / ON DEMAND

 Riduttore di portata / Flow regulator
5 l/min / 1.3 gpm

CEA

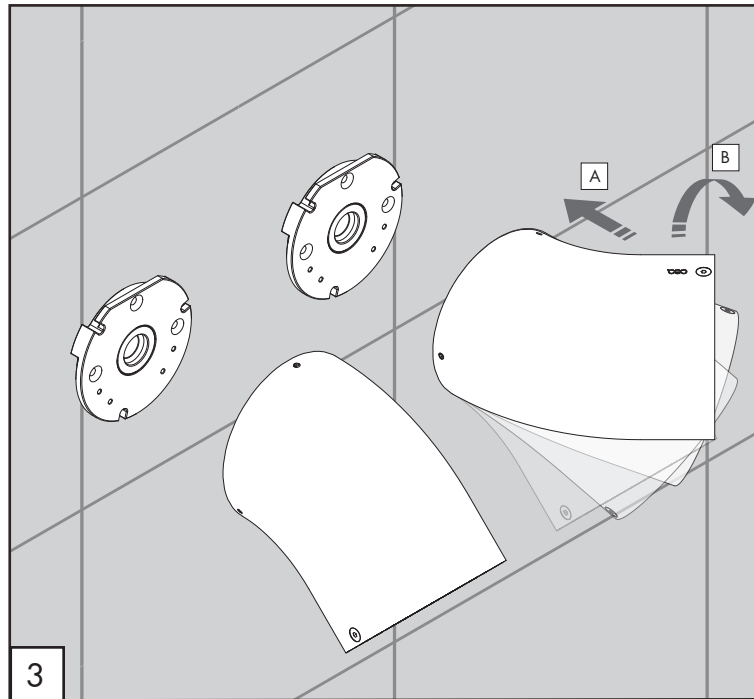
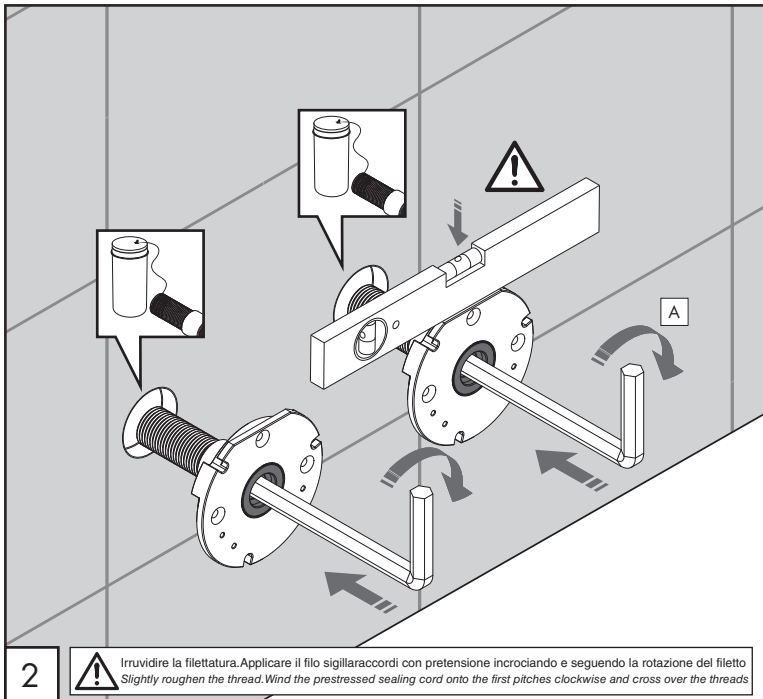
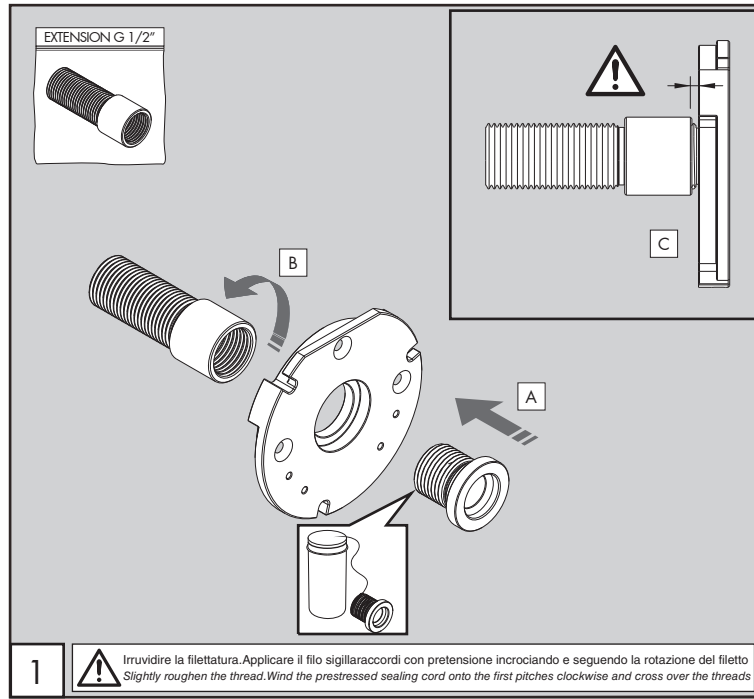
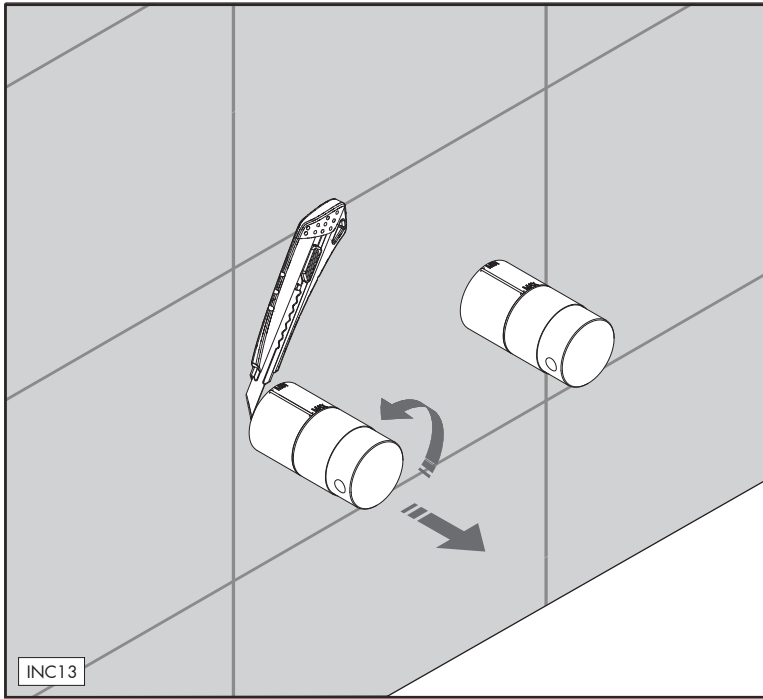

FRE183 _REV10

AVVERTENZE TECNICHE

Risciacquare bene le tubazioni prima del montaggio ed evitare sbalzi di pressione.

In caso di pressioni statiche superiori a 5 bar si raccomanda l'installazione di un riduttore di pressione per evitare danni al soffione.

TECHNICAL WARNINGS

The pipes have to be rinsed thoroughly before installation to avoid pressure differences.

Use of a pressure reducer when static pressure is higher than 5 bar to avoid damage of the shower head.

TECHNISCHE WARNUNG

Spülen Sie die Leitungen vor dem Einbau und verhindern Sie Wasserdruckwechsel.

Wenn Wasserdruck größer als 5 bar ist, bitte reduzieren Sie den Systemdruck, um Beschädigung der Kopfbrause zu verhindern.

ADVERTENCIA TÉCNICA

Purgar bien las tuberías antes de la instalación y evitar cambios bruscos de presión.



En caso de presión estática mayor de 5 bar, se recomienda el uso de un adaptador de presión para evitar daños en el rociador.

ADVERTISSEMENTS TECHNIQUES

Rincer les tuyaux avant l'installation. Eviter grandes différences de pression.

En cas de pressions statique de plus de 5 bar, nous vous recommandons d'installer un réducteur de pression pour éviter des dommages à la douche de tête.

TEMPERATURA DI ESERCIZIO / WORKING TEMPERATURE

 max. 70 °C
 max. 158 °F

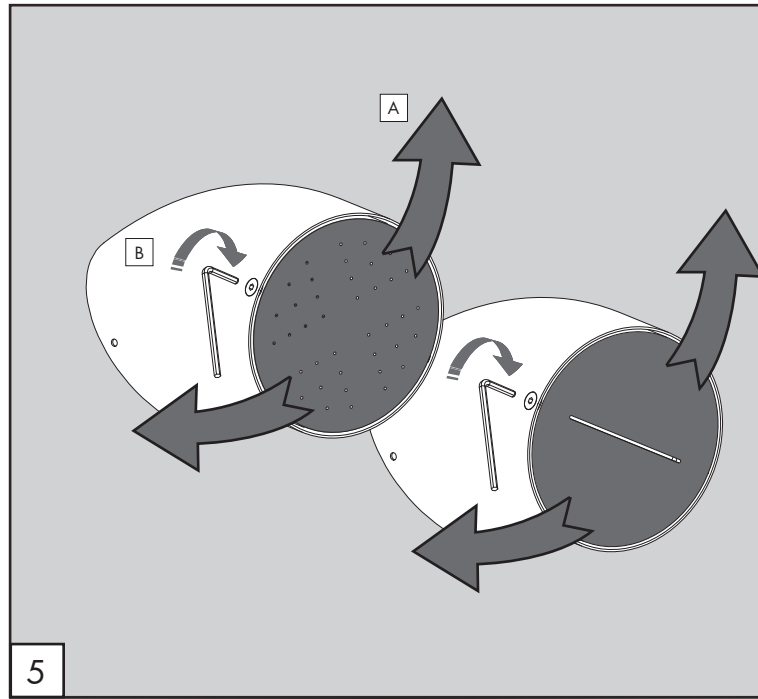
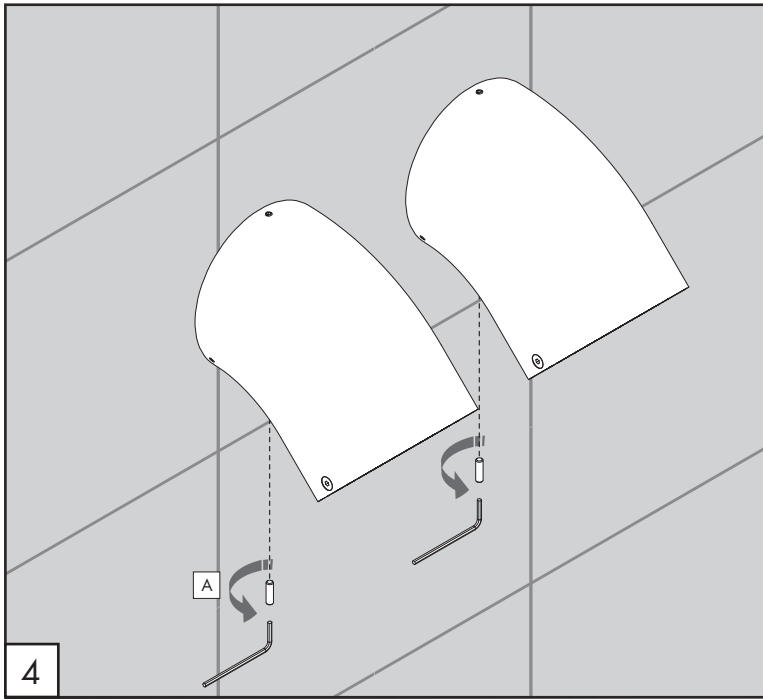

FRE183 _REV10

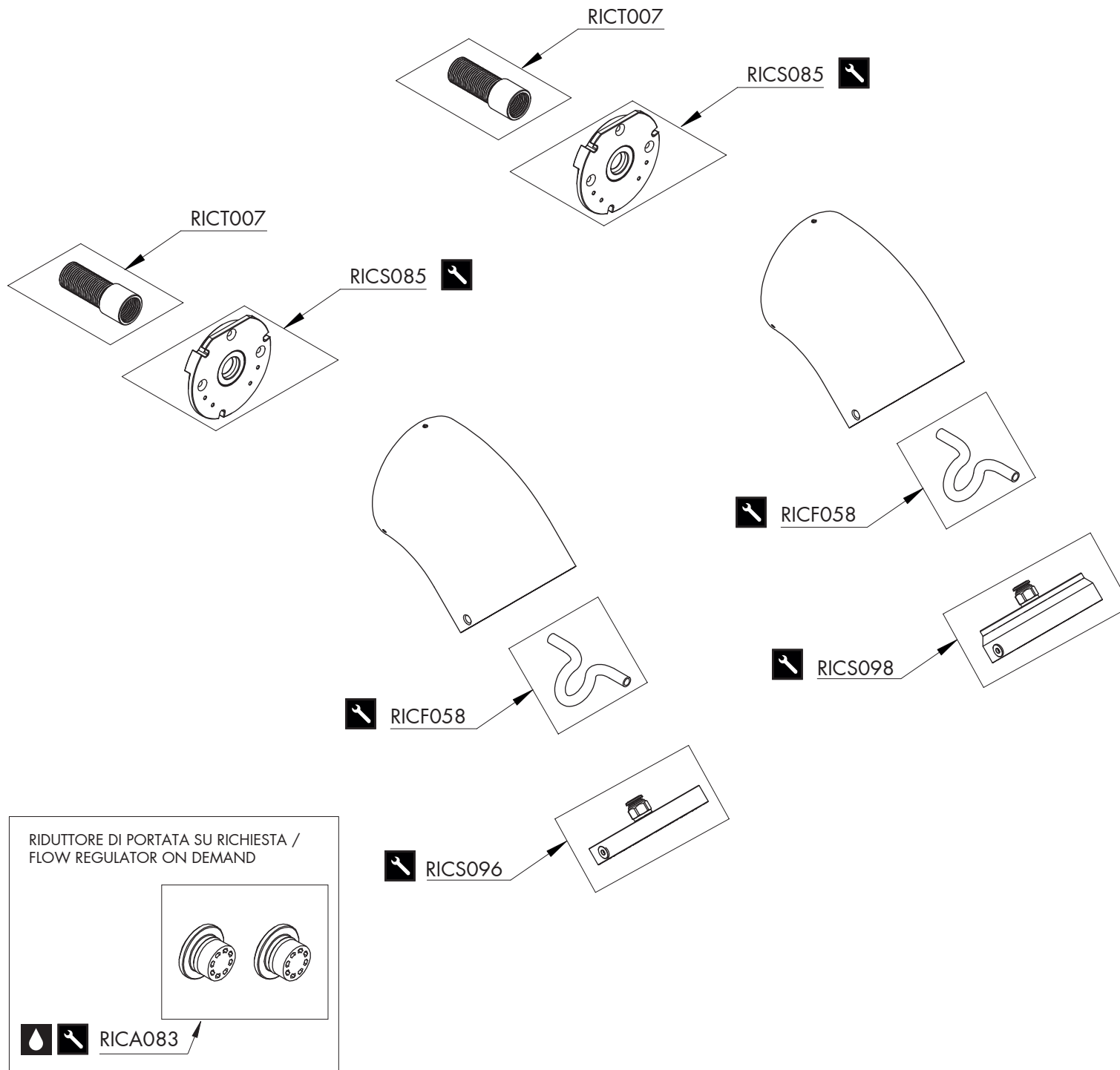

RICAMBI / SPARE PARTS

RICF058	Flessibile / Hose
RICS085	Flangia di fissaggio / Fastening flange
RICS096	Testa soffione / Head shower disk
RICS098	Testa soffione / Head shower disk
RICT007	Raccordo / Fitting

SU RICHIESTA / ON DEMAND

RICA083	Riduttore di portata / Flow regulator	5 l/min / 1.3 gpm
---------	---------------------------------------	-------------------



Conservare gli strumenti inclusi nel prodotto e utilizzati per l'installazione perchè riutilizzabili per i ricambi.

Please, keep the tools included in the item pack and employed for its installation, to re-used them for the spare parts.

Die Werkzeuge, die Sie für die Installation des Produktes benutzt haben, bitte aufbewahren, da sie auch für die Installation der Ersatzteile benutzt werden können.

No tirar las herramientas incluidas en el producto y usadas durante la instalación puesto que se pueden reutilizar para los recambios.

Veillez conserver les outils inclus dans la boîte du produit et employés pour son installation, parce que réutilisables pour les pièces de rechange.

LEGENDA / LEGEND

ICONE / ICONS



Riduttore di portata a risparmio idrico
Water saving flow regulator



Utensile incluso nel ricambio
Tool included in spare part

CEQ