

BAR34

_REV1.5

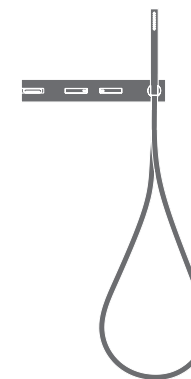

DESIGN
NATALINO MALASORTI



BAR34/BAR

AISI 316/L STAINLESS STEEL

Gruppo 2 miscelatori
idroprogressivi vasca con bocca
erogazione e doccia

Set of 2 hydroprogressive mixers
for bathtub with spout and hand
shower



PRODOTTI CORRELATI / RELATED PRODUCTS

FRE74 - MIL91



Insero bocca di erogazione, per il riempimento vasca
Spout insert, suitable for bathtub



Prodotto che necessita di parte incasso
Product that needs built-in part



Staffa ausiliaria per cartongesso / fibrogesso
Auxiliary bracket for plasterboard / fiber-board structures

MANUTENZIONE / MAINTENANCE

NON UTILIZZARE DO NOT USE		acido clorico e muriatico <i>chloric and muriatic acid</i>
		acido fluoridrico <i>hydrofluoric acid</i>
		ipoclorito di sodio <i>chlorine bleach</i>
UTILIZZARE TO USE		sapone a PH neutro <i>neutral PH soap</i>

Questi disegni sono proprietà di CEADDESIGN SRL s.u. pertanto non potranno essere utilizzati e/o comunicati a terzi, anche in forma parziale, senza preventiva autorizzazione. CEADDESIGN SRL s.u. si riserva il diritto di apportare modifiche ai disegni al fine di migliorare il prodotto.

CEADDESIGN SRL s.u. has the property rights on these drawings, therefore they cannot be used and/or transferred to third party, even in partial form, without any prior authorization. Furthermore CEADDESIGN SRL s.u. reserves the right to apply any change to these drawings in order to upgrade the product.



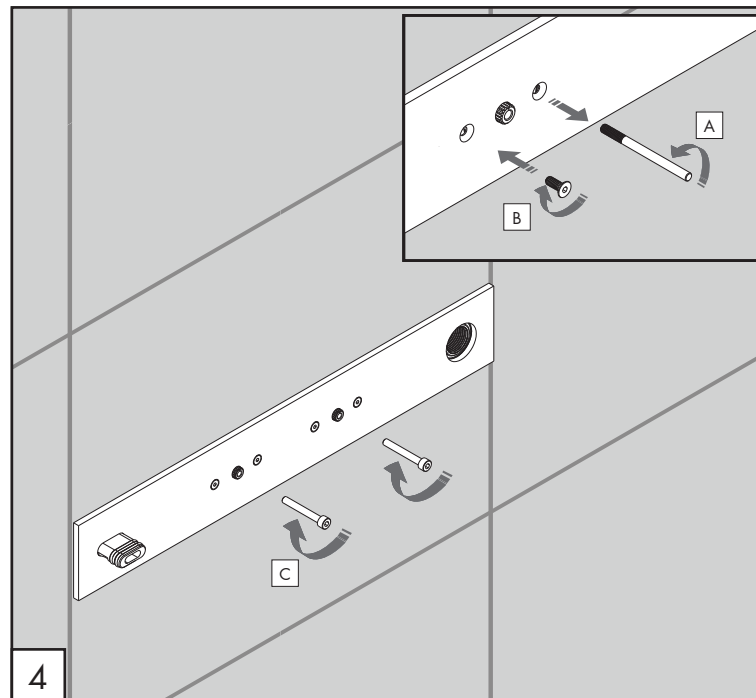
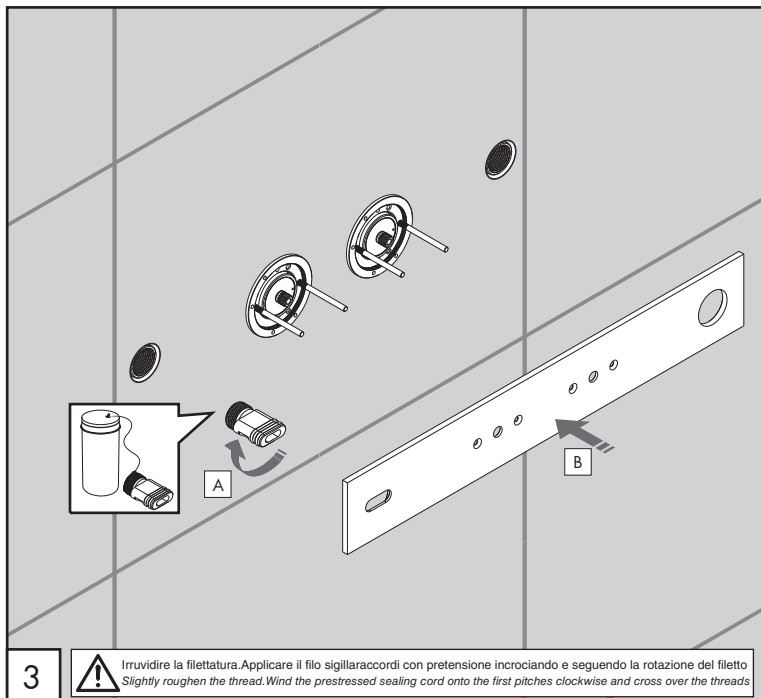
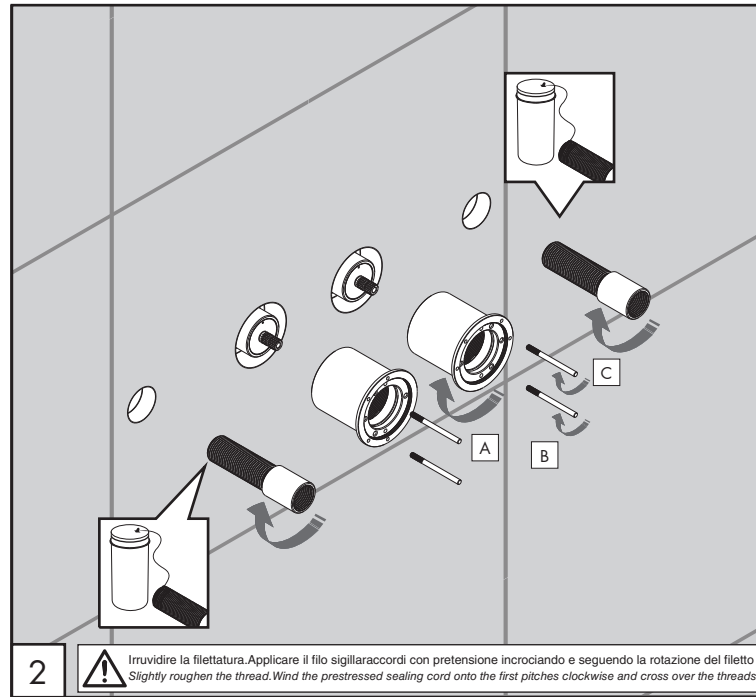
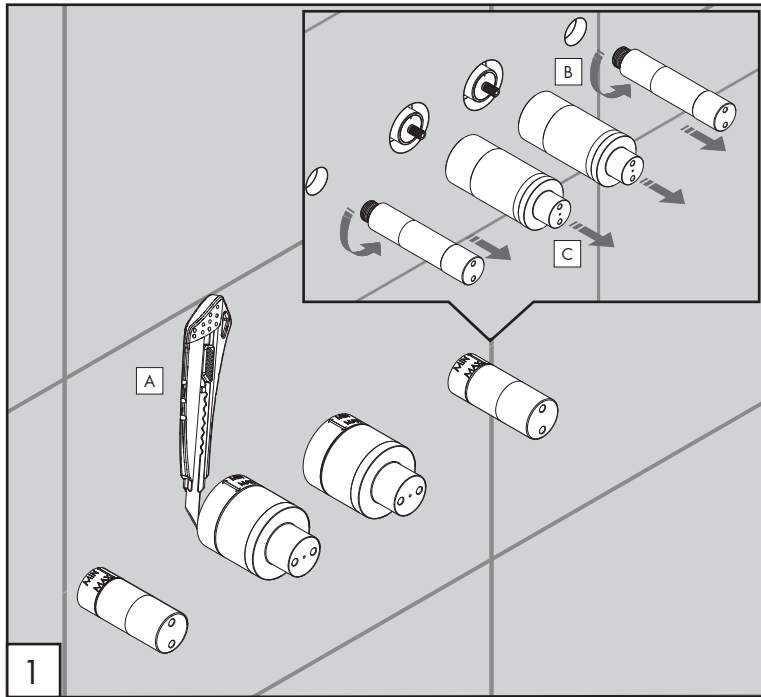

AVVERTENZE TECNICHE

Risciacquare bene le tubazioni prima del montaggio ed evitare sbalzi di pressione fra i raccordi d'acqua fredda e d'acqua calda. In caso di pressioni statiche superiori a 5 bar si raccomanda l'installazione di un riduttore di pressione per evitare danni alla cartuccia.

TECHNICAL WARNINGS

The pipes have to be rinsed thoroughly before installation. Avoid pressure differences between hot and cold water supply. Use of a pressure reducer when static pressure is higher than 5 bar to avoid damage of the cartridge.

TECHNISCHE WARNUNG

Spülen Sie die Leitungen vor dem Einbau und verhindern Sie Wasserdruckwechsel zwischen kalt und warm Wasserverbindungen. Wenn Wasserdruck größer als 5 bar ist, bitte reduzieren Sie den Systemdruck, um Beschädigung der Kartusche zu verhindern.

ADVERTENCIA TÉCNICA

Los tubos tienen que ser enjuagados a fondo antes de la instalación. Evitar grandes diferencias de presión entre las conexiones de agua caliente y fría. En caso de presión estática mayor de 5 bar, se recomienda el uso de un adaptador de presión para evitar daños en el cartucho.

ADVERTISSEMENTS TECHNIQUES

Rincer les tuyaux avant l'installation. Eviter des grandes différences de pression entre l'eau froide et chaude. En cas de pressions statique de plus de 5 bar, nous vous recommandons d'installer un réducteur de pression pour éviter des dommages à la cartouche.

TEMPERATURA DI ESERCIZIO / WORKING TEMPERATURE

max. 70 °C
 max. 158 °F

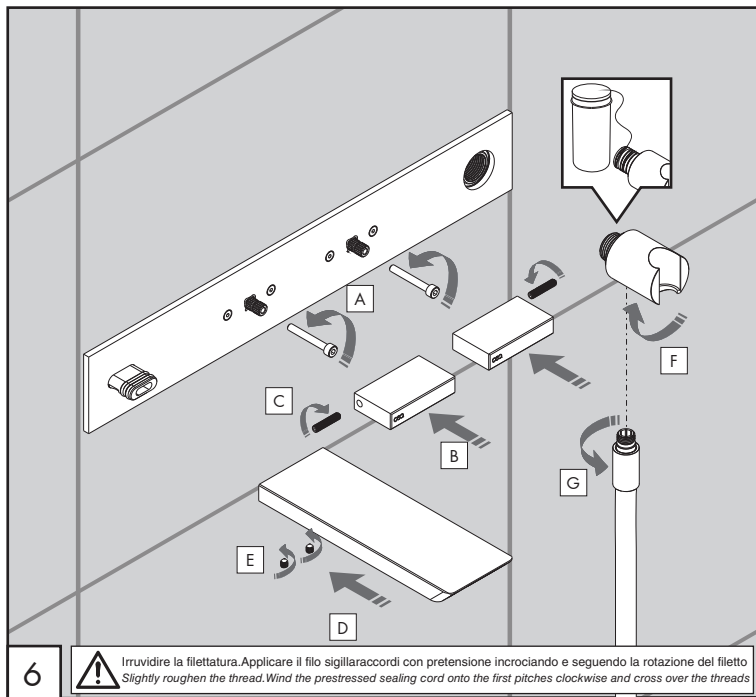
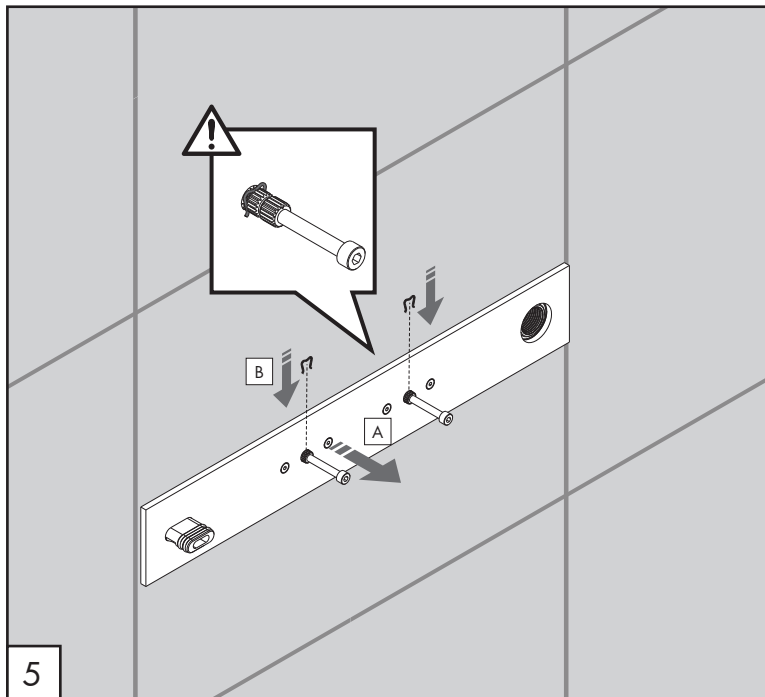

6  Irruvidire la filettatura. Applicare il filo sigillaraccordi con pretensione incrociando e seguendo la rotazione del filetto
Slightly roughen the thread. Wind the prestressed sealing cord onto the first pitches clockwise and cross over the threads

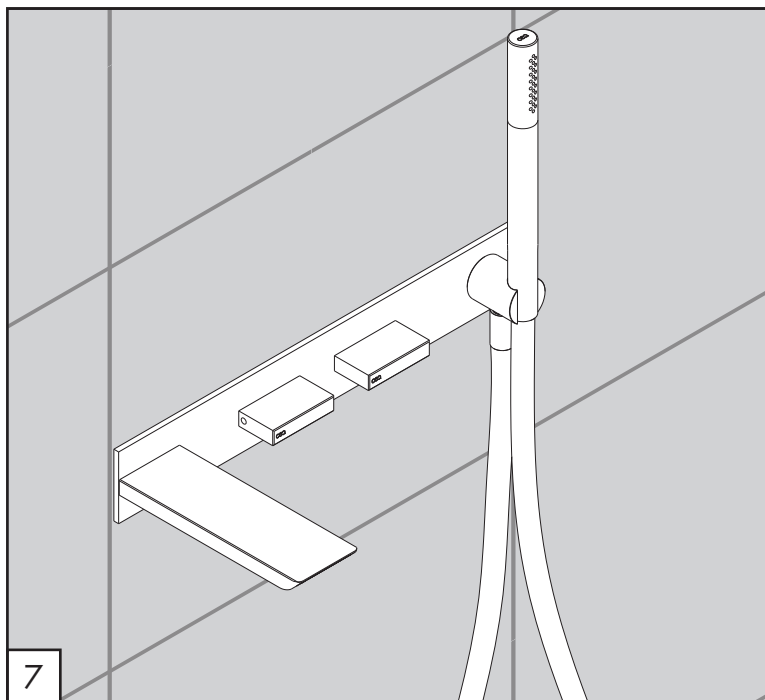

PULIZIA / CLEANING / SAUBEKEIT / LIMPIEZA / NETTOYAGE

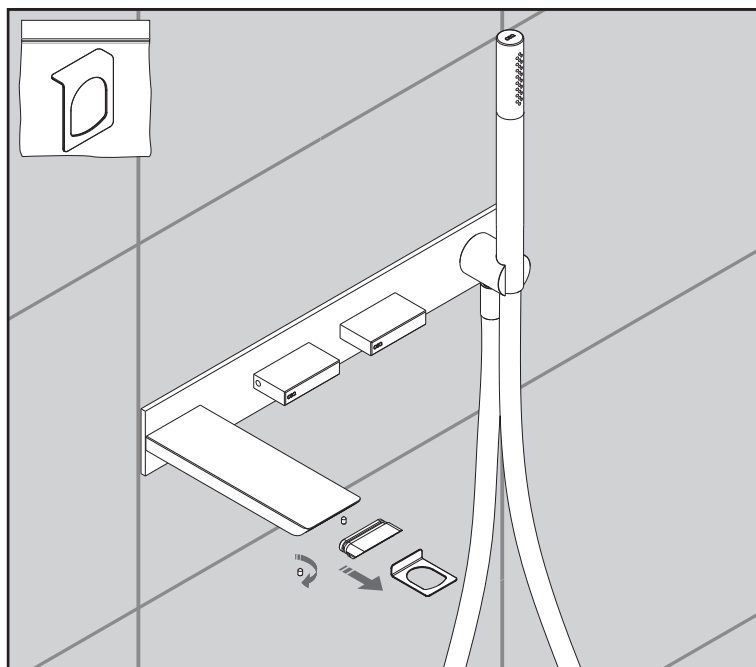

BAR34_REV1.5



Le portate indicate sono alla pressione consigliata di 3 bar
The indicated flow rates are at the recommended pressure of 3 bar

PORTATE DOCCINO / HAND SHOWER FLOW RATE

Acciaio inox / Stainless steel
14,7 l/min / 3.9 gpm

Gomma siliconica / Silicone rubber
11,4 l/min / 3 gpm

AERATORE IN DOTAZIONE / AERATOR INCLUDED

 Insetto bocca di erogazione / Spout insert
(21,2 l/min / 5.6 gpm)

CEQ

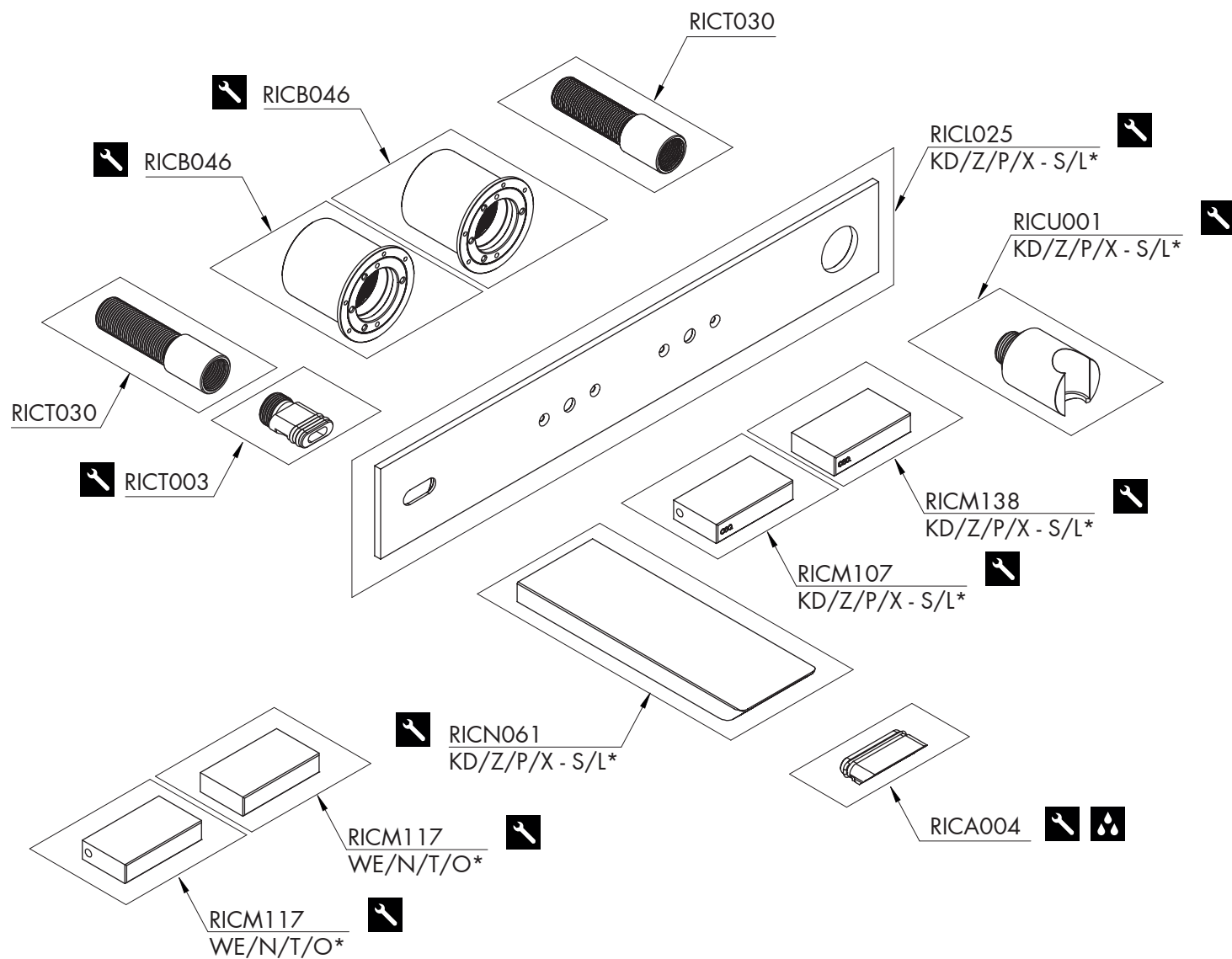

RICAMBI / SPARE PARTS

RICM107	Maniglia / Handle
RICM117	Maniglia / Handle
RICM138	Maniglia / Handle
RICN061	Bocca di erogazione / Spout
RICT003	Raccordo / Fitting
RICT030	Raccordo / Fitting
RICU001	Supporto doccia / Hand shower holder
RICA004	Inserto bocca di erogazione / Spout insert
RICB046	Carter / Carter
RICLO25	Piastra / Plate

LEGENDA / LEGEND

ICONE / ICONS

- Inserto bocca di erogazione, per il riempimento vasca
Spout insert, suitable for bathtub
- Utensile incluso nel ricambio
Tool included in spare part

FINITURE / FINISHES

- *S finitura satinata / *satin finish*
- L finitura lucidata / *polished finish*

FINITURE SPECIALI / SPECIAL FINISHES

- KD black diamond
- Z bronzo / *bronze*
- P rame / *copper*
- X light gold

ESSENZE LEGNO / WOOD ESSENCES

- *WE wengè / *wenge*
- N noce americano / *american walnut*
- T teak birmano / *burma teak*
- O rovere / *oak*

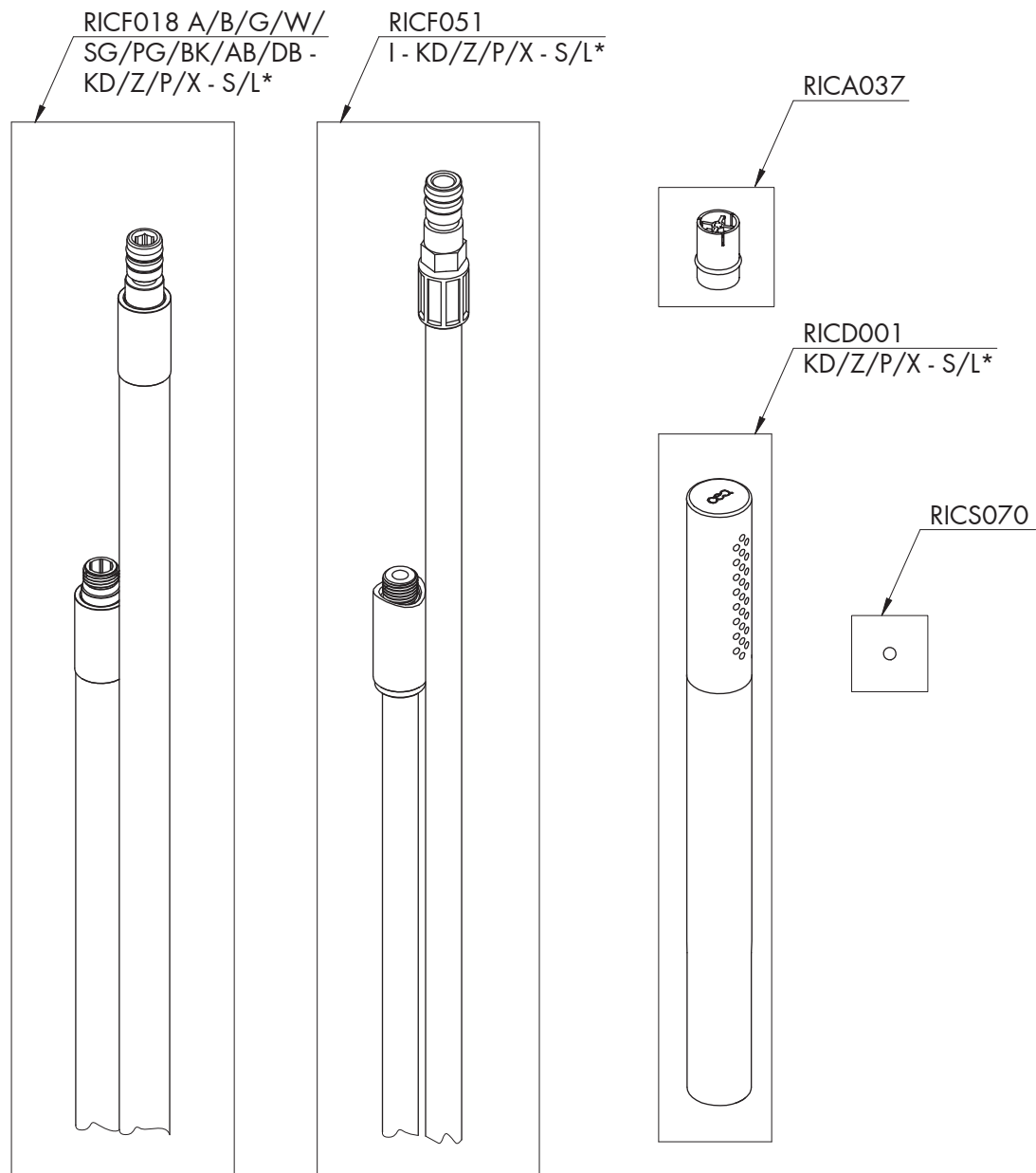

RICAMBI / SPARE PARTS

RICA037	Valvola di non ritorno / Check valve
RICD001	Doccino / Hand shower
RICF018	Flessibile / Hose
RICF051	Flessibile / Hose
RICS070	Sfera in acciaio inox Ø 3,5 mm Stainless steel ball Ø 3,5 mm

LEGENDA / LEGEND

ICONE / ICONS

 Utensile incluso nel ricambio
Tool included in spare part

FINITURE / FINISHES

*S finitura satinata / satin finish
L finitura lucidata / polished finish

FINITURE SPECIALI / SPECIAL FINISHES

KD black diamond
Z bronzo / bronze
P rame / copper
X light gold

COLORI FLESSIBILE / HOSE COLOURS

A	verde acqua / aqua green	RAL 6027
B	blu cobalto / cobalt blue	RAL 5013
G	grigio antracite / anthracite grey	RAL 7043
W	bianco / white	RAL 9016
SG	grigio seta / silk grey	RAL 7044
PG	verde petrolio / petroleum green	RAL 5020
BK	nero / black	RAL 9004
AB	blu avio / air force blue	RAL 5014
DB	grigio quarzo / quartz grey	RAL 7039
I	acciaio inox / stainless steel	